

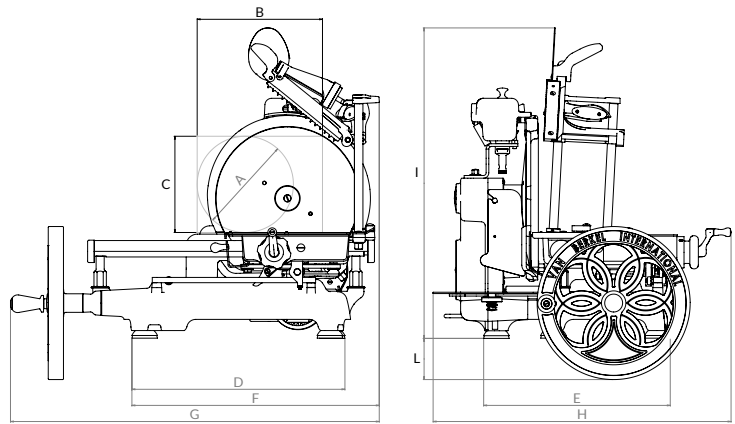

Berkel

ELEVATING YOUR PASSION, SINCE 1898.

VOLANO B114



	A	B	C	D	E	F	G	H	I	L	Ø Lama Ø Blade	Ø Lama Ø Blade	Ø Messer	Spessore taglio Cut thickness	Epaisseur de coupe Schnittbreite	Peso netto Net weight	Poids net Nettogewicht	Dimensione imballo Packaging dimensions	Dim. emballage Verpack. abmessungen	Piedistallo Stand	Socle Socket	Imballo piedistallo Stand packaging	Emballage Socle Socket Verpack.
	mm	mm	mm	mm	mm	mm	mm	mm	mm	mm	mm	mm	mm	mm	mm	kg	kg	cm - kg	cm - kg	cm - kg	cm - kg	cm - kg	
B114	215	280	215	470	415	555	825	670	700	95	319	319	319	0 - 1,5	0 - 1,5	55	55	86x79x66h - 65	58x58x78h - 45	58x58x78h - 45	70x73x100h - 76	70x73x100h - 76	

Listenpreis: 7940,34 Euro zzgl. Versand

VOLANO B3

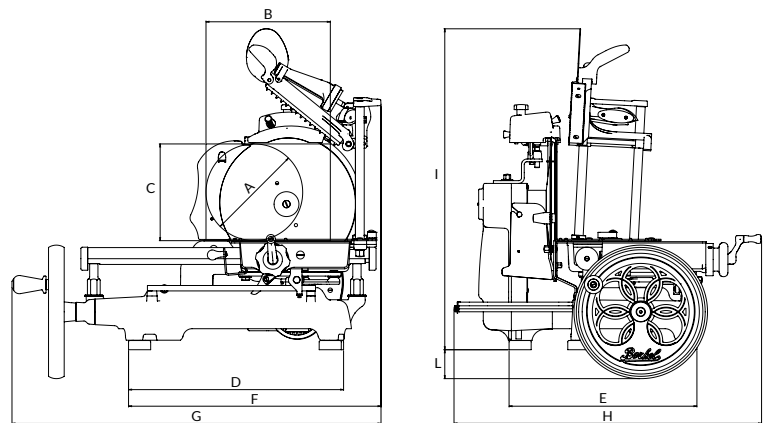

	A	B	C	D	E	F	G	H	I	L	Ø Lama Ø Blade Ø Lame Ø Messer	Spessore taglio Cut thickness Epaisseur de coupe Schnittbreite	Peso netto Net weight Poids net Nettogewicht	Dimensione imballo Packaging dimensions Dim. emballage Verpack. abmessungen	Piedistallo Stand Socle Sockel	Imballo piedistallo Stand packaging Emballage Socle Sockel Verpack.
	mm	mm	mm	mm	mm	mm	mm	mm	mm	mm	mm	mm	kg	cm - kg	cm - kg	cm - kg
B3	210	270	210	460	405	550	805	670	700	65	300	0 - 1,5	46	86x79x66h - 56	58x58x78h - 45	70x73x100h - 76

Listenpreis: 6320,19 Euro zzgl. Versand

VOLANO B2

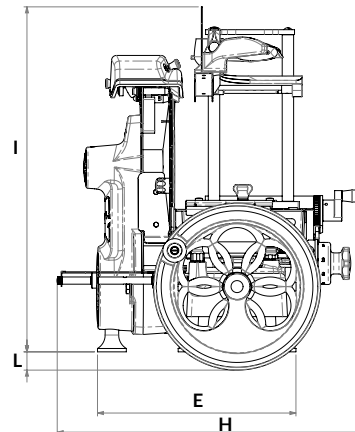
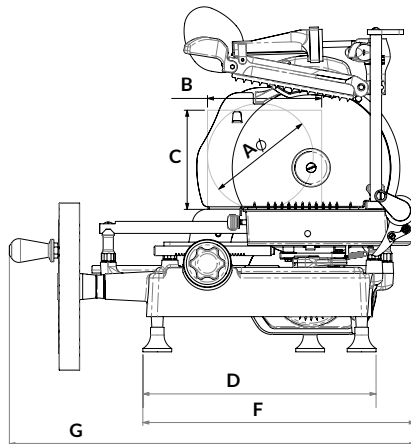

	A	B	C	D	E	F	G	H	I	L	Ø Lama Ø Blade Ø Lame Ø Messer	Spessore taglio Cut thickness Epaisseur de coupe Schnittbreite	Peso netto Net weight Poids net Nettogewicht	Dimensione imballo Packaging dimensions Verpack. abmessungen Dim. emballage	Piedistallo Stand Socle Sockel	Imballo piedistallo Stand packaging Emballage Socle Sockel Verpack.
B2	176	190	165	395	330	460	675	530	570	33	265	0 - 1,35	33	86x79x66h - 50	58x58x78h - 45	70x73x100h - 76

Listenpreis: 5957,14 Euro zzgl. Versand

RED LINE 250

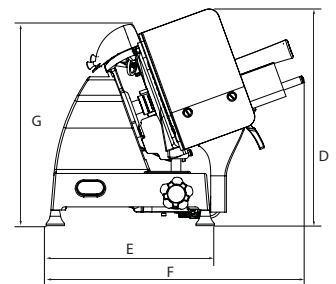
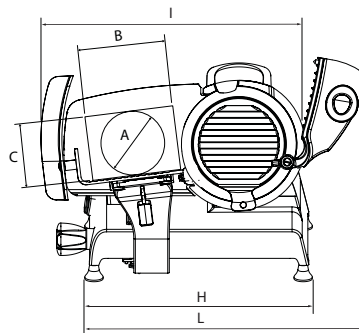
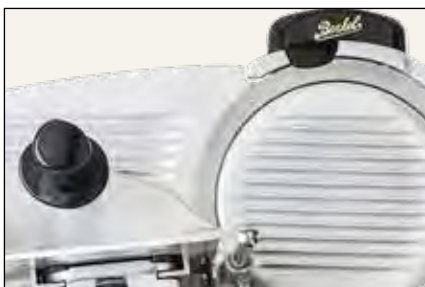

	A	B	C	D	E	F	G	H	I	L	Ø Lama Ø Blade	Ø Lama Ø Blade	Ø Messer	Spessore taglio Cut thickness Epaisseur de coupe Schnittbreite	Peso netto Net weight Poids net Nettogewicht	Potenza motore Motor rating Puisissance moteur Motorleistung	Specifiche elettriche Electrical specifications Caractéristiques électriques Elektrische Eigenschaften
	mm	mm	mm	mm	mm	mm	mm	mm	mm	mm	mm	mm	mm	kg	kW	V - Hz	
RL250	178	185	175	420	320	505	390	435	515	580	250	250	14	22	0,19	230 - 50	

Listenpreis: 906,72 Euro zzgl. Versand

RED LINE 300

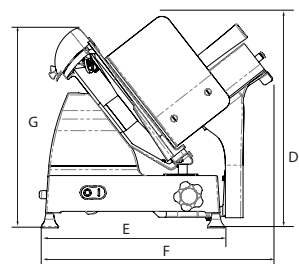
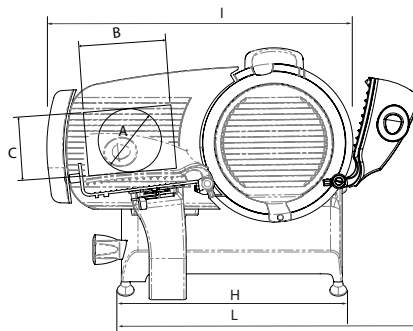

	A	B	C	D	E	F	G	H	I	L	Ø Lama Ø Blade	Ø Lame Ø Messer	Spessore taglio Cut thickness Épaisseur de coupe Schmittbreite	Peso netto Net weight Poids net Nettogewicht	Potenza motore Motor rating Puissance moteur Motorleistung	Specifiche elettriche Electrical specifications Caractéristiques électriques Elektrische Eigenschaften
	mm	mm	mm	mm	mm	mm	mm	mm	mm	mm	mm	mm	mm	kg	kW	V - Hz
RL300	230	245	225	480	380	475	430	485	635	630	300	0 - 14	27	0,31	230 - 50	

Listenpreis: 1394,12 Euro zzgl. Versand

XS25-30

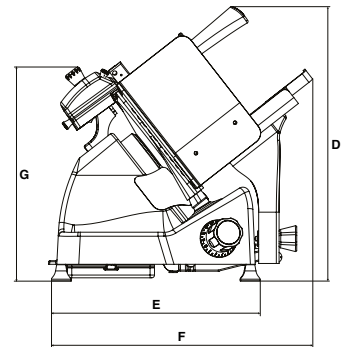
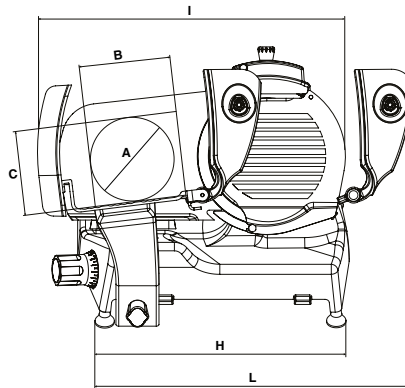

A	B	C	D	E	F	G	H	I	L	Ø Lama Ø Blade	Spessore taglio Cut thickness Épaisseur de coupe Schnittbreite	Peso netto Net weight Poids net Nettogewicht	Potenza motore Motor rating Puissance moteur Motorleistung	Specifiche elettriche Electrical specifications Caractéristiques électriques Elektrische Eigenschaften
mm	mm	mm	mm	mm	mm	mm	mm	mm	mm	mm	mm	kg	kW	V - Hz

XS25	188	225	178	505	378	480	445	450	565	575	250	0 - 14	19	0,33	230/50/1
XS30	230	245	195	545	415	595	435	506	640	645	300	0 - 14	29	0,35	230/50/1

Listenpreis XS25: 839,50 Euro zzgl. Versand
 Listenpreis XS30: 1301,68 Euro zzgl. Versand

Listenpreis XS25 rot: 1057,98 Euro zzgl. Versand
 Listenpreis XS30 rot: 1461,34 Euro zzgl. Versand

GERMAN 25-30

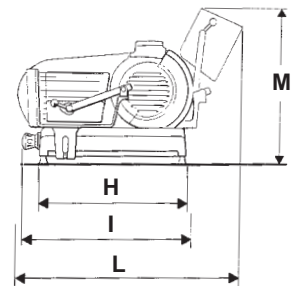
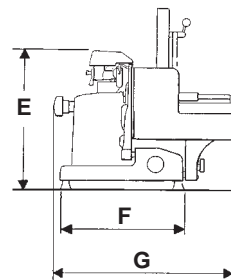
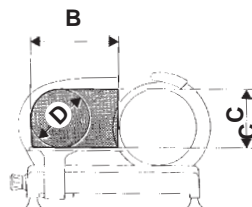

	B	C	D	E	F	G	H	I	L	M	Ø Lama Ø Blade Ø Lame Ø Messer	Spessore taglio Cut thickness Epaisseur de coupe Schnittbreite	Peso netto Net weight Poids net Nettogewicht	Potenza motore Motor rating Puissance moteur Motorleistung	Specifiche elettriche Electrical specifications Caractéristiques électriques Elektrische Eigenschaften
	mm	mm	mm	mm	mm	mm	mm	mm	mm	mm	mm	mm	kg	kW	V - Hz
GERMAN 25	230	180	180	440	350	510	440	630	740	550	250	0 - 14	27	0,3	230/50/1 - 400/50/3
GERMAN 30	260	230	230	480	400	570	520	650	820	570	300	0 - 14	37	0,3	230/50/1 - 400/50/3

Listenpreis German25: 2268,79 Euro zzgl. Versand
 Listenpreis German30: 2493,31 Euro zzgl. Versand

ZUBEHÖR



Schürze Volano

Schürze aus reiner Baumwolle mit goldfarbener BERKEL-Logostickerei. Hergestellt aus strapazierfähigem Garn in der Farbe Antikes Berkel-Rot.

Listenpreis: 25,21 Euro



Schneidebrett Volano

Qualität, Ihr Lebensstil. Das Schneidebrett für die VOLANO Linie in seiner klassischen Form aus Buchenholz.

Abmessungen: 395 x 200 x 25 mm

Listenpreis: 83,12 Euro



Schneidebrett elekt. Aufschnittmaschine

Schneidebrett für Red Line 220 und 250, aus Escheholz und Metall, die berühmte Berkel Signatur am Rand des Holzplatte.

Abmessungen: 290 x 205 x 24 mm

Listenpreis: 108,40 Euro



Flightcase für Volano B114 / Tribute / B3

Sichere Transportbox für Volano Maschinen aus Risopal und Metall.

Abmessungen: 63 x 65 x 100 cm (klein), 75x90x85 cm (groß)

Listenpreis: 1511,16 Euro (STAND) / 1841,90 Euro (Maschine)



Pflegeset

- Mittelgroßes Tuch aus MICROFASER
- Desinfektions-Spray 250 ml
- Schmieröl-Spray 200 ml
- Bürste zur Messerreinigung
- rote Box Kirsche Papier

Preis: 74,99 Euro

Restoring Kit (rot/schwarz)

- Mittelgroßes Tuch aus MICROFASER
- Schmieröl-Spray 200 ml
- Bürste zur Messerreinigung
- Retusche Lackstift
- rote Box Kirsche Papier

Preis: 83,9 Euro



Sockelheber für Volano Maschinen

Kompakter Fahrwagen mit einer Gabelhubeinheit zum einfachen Anheben eines Berkel Sockels.

Maße: 600x480x100mm (ohne Hebel)
Gabelbreite: 290mm
Gabelzwischenmaß: 140mm
Gabellänge: 480mm

Listenpreis: 1315,00 Euro zzgl. Versand

TS 8E - TL 12E

TRITACARNE / MEAT MINCER /
HACHOIR À VIANDE / FLEISCHWOLF



DE - Profi-Fleischwölfe, ideal für kleine Restaurantbetriebe und Trattorias. Korpus mit einer Legierung aus eloxiertem Aluminium, Trichter, Platte und Messer aus Edelstahl. Mit Umkehrvorrichtung, Motorschutz (in der Einphasen-Version) und thermischer Sicherheitsvorrichtung.

OPTIONAL

45 - 67 - 96 - 237



	Potenza Power Puissance Spannung	Alimentazione Power source Alimentation Betriebsspannung	Produzione oraria Output/h. Débit/h. Leistung/h.	Peso Weight Poids Gewicht	A	B	C
	W	Volt	kg/h	kg	mm	mm	mm
TS 8E	500 600	230/50/1 400/50/3	50/80	13	170	380	210
TL 12E	500 600	230/50/1 400/50/3	100/120	14	170	380	210

Listenpreis TS8E: 1296,89 Euro zzgl. Versand

Listenpreis TL12E: 1395,31 Euro zzgl. Versand

Listenpreis TS8E(rot): 1296,89 Euro zzgl. Versand

TS 12E - TL 22E

TRITACARNE / MEAT MINCER /
HACHOIR À VIANDE / FLEISCHWOLF



DE - Professioneller Tischfleischwolf, perfekt für Fleischereien, Supermärkte und Zerlegungsbetriebe. Korpus mit einer Legierung aus eloxiertem Aluminium; Öffnungen aus Edelstahlglas. Ausgestattet mit Umkehrvorrichtung und Vorrüstung für System UNGER.

OPTIONAL

45 - 66 - 67 - 96 - 237 - 238

IT Disponibile in rosso
EN Available in red
FR Disponible en rouge
DE Auf Anfrage in rot

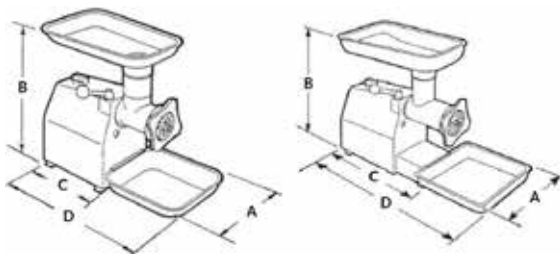

	Potenza Power Puissance Spannung	Alimentazione Power source Alimentation Betriebsspannung	Produzione oraria Output/h. Débit/h. Leistung/h.	Peso Weight Poids Gewicht	A	B	C	D
	W	Volt	kg/h	kg	mm	mm	mm	mm
TS 12E	750 1450	230/50/1 400/50/3	150/170	22	220	430	250	490
TL 22E	750 1450	230/50/1 400/50/3	200/230	24	220	430	360	220

Listenpreis TS12E: 1832,05 Euro zzgl. Versand
Listenpreis TL22E: 2068,87 Euro zzgl. Versand

INT 90E - TAG - IM4 - TM

INTENERITRICE TAGLIASTRISCE / TENDERISER STRIP CUTTING MACHINE / STREIFENSCHNEIDER UND MÜRBER / ATTENDRISSEUR ET COUPE-VIANDE



DE - Professioneller Mürber aus eloxiertem Aluminium und Edelstahl. Leistungsstarker Drehstrommotor, vollkommen hermetisch und mit einem Kühlsystem mit Zwangsluftstrom. Ölbadgetriebe.

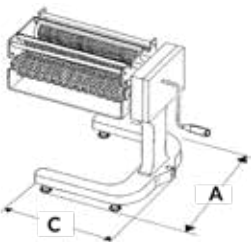
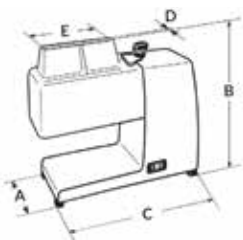

OPTIONAL INT90
68 - 69 - 94 - 121

OPTIONAL IM4
69

OPTIONAL TAG
68 - 84 - 94 - 121

OPTIONAL TM
84

	A	B	C	D	E
	mm	mm	mm	mm	mm
INT 90E	200	440	450	20	180
TAG	200	440	450	20	180
IM 4 / TM	270		330		

	Potenza Power Puissance Spannung	Alimentazione Power source Alimentation Betriebsspannung	Velocità Speed Vitesse Schnell	Peso Weight Poids Gewicht
	W	Volt	kg/h	kg
INT 90E	400	120/60/1 220/60/1 230/50/1	20cm/sec.	23
TAG	500	400/50/3	20cm/sec.	23

Listenpreis INT90E: 3502,12 Euro zzgl. Versand
Listenpreis TAG: 3341,16 Euro zzgl. Versand
Listenpreis IM4: 1473,23 Euro zzgl. Versand
Listenpreis TM: 1359,43 Euro zzgl. Versand

BT 10 - 13 - OVAL

HAMBURGATRICE / HAMBURGER FORMING MACHINE /
PRESSE À HAMBURGER / HAMBURGERMASCHINE



DE - Hamburgermaschine, ideal für Restaurants und Schlachtereien. Presse aus eloxiertem Aluminium, die mit dem Fleisch in Berührung stehenden Teile sind aus Edelstahl und können ohne jegliches Werkzeug ausgebaut werden. Automatische Seitenöffnung des Niederhalters. Für die bequeme Entnahme wird der Hamburger nach oben gedrückt

IT Disponibile in rosso
EN Available in red
FR Disponible en rouge
DE Auf Anfrage in rot



Dimensioni hamburger
Dimensions hamburger
Dimensions hamburger
Abmessungen hamburger

		A	B	C
BT 10	Ø 10 cm	150 mm	260 mm	200 mm
BT 13	Ø 13 cm	150 mm	260 mm	200 mm
BT 10	11x8 cm	150 mm	260 mm	200 mm

Listenpreis BT10: 408,03 Euro zzgl. Versand

Listenpreis BT13: 431,61 Euro zzgl. Versand

Listenpreis OVAL: 431,61 Euro zzgl. Versand

Listenpreis BT10 (rot): 408,03 Euro zzgl. Versand

Listenpreis BT13 (rot): 431,61 Euro zzgl. Versand

FP 35 - 50

CUTTER



DE - Professionelles Gerät zum Hacken, Mischen und Homogenisieren jeglicher Produktarten. Der Behälter ist für eine einfache Reinigung innen abgerundet und hat einen Thermoboden, um auch direkt auf dem Herd verwendet werden zu können. Behälter und Schneidesatz aus Edelstahl. Transparente Plexiglas-Abdeckung mit Öffnung.

IT Disponibile in rosso
 EN Available in red
 FR Disponible en rouge
 DE Auf Anfrage in rot



	Potenza Power Puissance Spannung	Alimentazione Power source Alimentation Betriebsspannung	Capacità (l/) Capacity (l/) Capacité (l/) Kapazität (l/)	Peso Weight Poids Gewicht	A	B	C
	W	Volt	kg/h	kg	mm	mm	mm
FP 35	400	230/50/1 120/50/1	3,5	12	190	290	290
FP 50	400	230/50/1 120/50/1	5	13	200	360	280

Listenpreis FP35: 959,60 Euro zzgl. Versand

Listenpreis FP50: 1109,28 Euro zzgl. Versand

Listenpreis FP35(rot): 959,60 Euro zzgl. Versand

Listenpreis FP50(rot): 1109,28 Euro zzgl. Versand

Van Berkel International S.r.l.
via Ugo Foscolo, 22
21040 Oggiona S. Stefano (Va) - Italy
T. +39 0331 214311
info@berkelinternational.com
theberkelworld.com